



KENAITZE INDIAN TRIBE
Invitation to Bid (ITB)
Project BIA Single Family Home
Issued: Date October 7, 2024

1 INTRODUCTION

1.1 ORGANIZATION

1.1.1 The Kenaitze Indian Tribe is a federally recognized tribal government, re-organized in 1971 under the statutes of the Indian Reorganization Act of 1934, as amended for Alaska in 1936. The Tribe serves over 5,000 community members, Alaska Natives, and American Indians in the central and upper Kenai Peninsula. The Tribe's Headquarters is located at 150 N Willow, Kenai, Alaska 99611. Nothing in this ITB is a waiver of the Tribe's sovereign immunity.

1.2 MISSION STATEMENT

1.2.1 To assure Kahtnuht'ana Dena'ina thrive forever.

2. OVERVIEW

The Kenaitze Indian Tribe ("Kenaitze" or "Tribe") is a Federally recognized Indian tribe that operates certain federal programs, services, functions, and activities under a Self-Governance compact and annual funding agreement pursuant to Title IV of the Indian Self-Determination and Education Assistance Act, P.L. 93-638, as amended.

Kenaitze is seeking proposals from Contractors qualified and interested in providing contractor services for the construction of an ADA single-family home (hereafter referred to as "the Project"). The selected Contractor shall provide professional oversight and delivery of all aspects of the construction services required to complete the Project successfully, on time, and within the Project's budget.

The selected firm is expected to enter into a legally binding Agreement with the Tribe based on a relationship of trust and confidence. The selected firm is further expected to use its highest skill and judgment to design and build the Project while remaining in close consultation with the Tribe to ensure the successful completion of the Project. The selected firm shall provide for the professional oversight and delivery of all aspects of the services required to complete the Project successfully, on time, and within the Project's budget, in accordance with the terms and conditions of the Tribe's Standard Professional Service Agreement. (Attachment B).

The Tribe is constructing the Project using the Housing Improvement Program Funds of the Bureau of Indian Affairs (BIA). The Project shall be conducted in accordance with all applicable Tribal, Federal, State, and Local Laws and Regulations and the terms of the Funding Agreement.

3. INQUIRIES

Questions regarding this ITB must be directed in writing to Tami Murray, Procurement Manager, TMurray@kenaitze.org. All emails must identify the ITB title in the subject line, include the contact information for the person submitting the question, and indicate the relevant ITB, Plan Page, or Specification Division section number.

All questions must be submitted using this format and must be received no later than 5:00 p.m. (Alaska Standard Time) on October 16, 2024. Responses will be posted on the Kenaitze website on or before the close of business on October 18, 2024, and emailed to inquiring parties.

The post will provide every question received and each accompanying response. This will ensure all potential Offerors receive the same information. Questions will only be answered in writing. Revisions to this ITB shall only be made through formal written addenda that will be made available to all interested Offerors as described above. Oral and other interpretations or clarifications will be without legal effect. It is the Offeror's responsibility to ensure they are on the Tribe's list to receive all addenda.

Offerors must read the ITB thoroughly. Any ambiguity, conflict, discrepancy, omission, or other errors in this ITB must be reported in writing. Any changes or corrections to the ITB will be made only by a written addendum issued by the Tribe. Failure to report ambiguities, conflicts, discrepancies, omissions, or other errors in a timely manner prior to submission of the proposals will result in a waiver of those issues.

4. PROPOSAL SUBMISSION REQUIREMENTS

All contractors interested in submitting a proposal in response to this ITB must adhere to the following requirements. Failure to do so may result in the Tribe deeming the proposal non-responsive and, therefore, not eligible for consideration.

4.1 Proposal Submittal Items

Contractors must only submit one proposal, follow the format outlined below, and clearly identify each of the following four criteria within the submittal.

- a) Cover Letter** – Submit a cover letter on company letterhead that is no more than 1 page and includes the following:
 1. The company's legal name and contact information.
 2. An overview of the company's qualifications and experience relevant to the scope of work defined herein.
 3. The letter must be signed by an authorized company representative and include that person's contact information.

4. Contractor must confirm its ability to secure a performance bond and a payment bond, each in an amount equal to 100% of the contract price, as security for the faithful performance and payment of the contractor's obligations under the agreement.
- b) **Scope of Work** – Submit a written, detailed description of how each subsection within section 5 Scope of Work will be accomplished. Please refrain from using marketing information in this part of the proposal submittal.
- c) **Deliverables** – If necessary and/or required, submit a schedule of all deliverables and milestones/due dates.
- d) **Price** – Submit a written price proposal to provide the service(s) as specified herein, using the format set forth in subsection 7.1 Proposal Price. The proposed price must include all of the contractor's costs associated with providing the good(s) or service(s) as called for within this ITB and including, but not limited to, wages, administrative overhead, travel, transportation, lodging, and other similar costs unless stated otherwise. No other costs will be considered for payment.
- e) Offer references for three similar projects with similar scope and budget.
- f) All proposals will become the property of the Tribe and may be returned only at the option of the Tribe. Any information marked as proprietary or confidential will be held in confidence to the greatest extent possible.

4.2 Proposal Submission Deadline

To be considered, a complete proposal package must be received by the Tribe by the deadline via either of the following methods:

Hand-delivered or mailed to: Kenaitze Indian Tribe
Attention: Tami Murray
Procurement Manager
150 N Willow St
Kenai, Alaska 99611

Electronically transmitted to: tmurray@kenaitze.org

The deadline for submission is 5:00 p.m. Alaska Time, November 1, 2024. Proposals received after the deadline may not be accepted. Proposals sent via email should be in a single PDF document format, with the ITB title noted in the subject line. **The Notice of Award is anticipated on November 11, 2024.**

By submitting a proposal, the Offeror represents that they become familiar with local conditions and have correlated that knowledge with the requirements in this ITB. To make a site visit, please contact Tami Murray, Procurement Manager, at TMurray@kenaitze.org.

4.3 Proposal Preparation Cost

The Tribe shall not be responsible for any costs associated with preparing and/or submitting a proposal in response to this ITB, in any manner or for any reason.

4.4 Proposal Validity

Offeror's price proposal will remain valid for 90 calendar days from the ITB submission deadline or until an award is made to the successful contractor, whichever is sooner. No price proposal will be accepted if marked "price prevailing at time of delivery", "estimated price", or something similar. All price proposals must be in US dollars.

4.5 Contract Terms

Within 30 calendar days after a contractor is selected and a notice of intent to award is issued, it is expected that the selected contractor will sign the Tribe's standard Agreement for Professional Services, which is included as an attachment to this ITB (Attachment B).

Interested contractors are expected to carefully review the Tribe's standard Agreement and advise the Tribe—as a required part of the proposal—if any of the terms or conditions of the Agreement are objectionable. If any provisions are objectionable, the contractor must propose alternative terms and conditions which are acceptable to it. These pages will not count against the proposal page limit. The Tribe reserves the right to reject any proposal that fails to indicate that the contractor is willing to execute the Tribe's standard Agreement or fails to propose terms and conditions for the Agreement that are acceptable to the Tribe.

5. SCOPE OF WORK

5.1 The Contractor shall provide all materials and perform and complete work required for the construction of an 800-square foot ADA accessible single-family home for a tribal elder located at Scooter's Replat Lot 1A Block 1 (Parcel 06345409) on Robinson Loop Road in Sterling, AK, known as the Project. A set of drawings shall be dated and initialed by both parties on each page. The Owner shall retain the dated and initialed set of drawings.

The selected Contractor shall provide professional oversight and delivery of all aspects of the construction services required to complete the Project. The terms of the Tribe's BIA Home Improvement Grant require the Tribe to complete an environmental review in accordance with the requirements of 24 CFR §§ 1000.18–1000.24 prior to undertaking construction activities. The Tribe is in the process of completing the required review and will promptly provide the results of the review to the selected Contractor once available.

5.1 Objectives – The Tribe has identified the following to include but are not limited to objectives and services for the selected Contractor for the project:

1. This will be a turnkey job to include the house from footing to finish. Contractor shall bid to furnish all necessary labor, quality control, licenses, material, equipment, tools, supplies, permits, and insurance and supervision to perform the work required thereof within the time specified after the receipt of "Notice to proceed".
2. General construction conforms to applicable tribal, borough, state, or national codes and to appropriate building code standards for the region.
3. Heating systems to be supplied by Contractor.

4. The heating system must be able to maintain a minimum temperature of 70 degrees in the house during the coldest weather in the area, be safe to operate and maintain, and deliver a uniform heat distribution. Oil is the preferred fuel source.
5. Stove/Oven to be supplied by Contractor, propane preferred.
6. All plumbing fixtures, including but not limited to tub, shower, sinks, and faucets to be supplied by Contractor.
7. Contractor to perform land clearing at the project site that results in an area free and clear of vegetation and/or debris and is suitable for construction.
8. Construct a foundation and structure, in accordance with the provided construction drawings, that results in an 800-square-foot ADA Accessible single-family home or present a suitable option for consideration.
9. Contractor is responsible for temporary utilities **(Do not tie into families' existing services)**
10. Contractor is responsible for building permits, inspection fees and meeting all city/state building codes and covenants if applicable.
11. Contractor to coordinate and perform the installation of all exterior and interior components identified in the engineered and non-engineered drawings.
12. Contractor to relocate all utilities using the existing septic and well.
13. Contractor must give a minimum of 30 days' notice when relocating utilities (the homeowner resides on the property in an existing mobile home)
14. Contractor must coordinate and perform inspections throughout the project, including a final walk-through with Tribal representatives.
15. At various stages of construction, a trained and qualified representative of the Tribe will review the work to ensure that it meets construction standards and building codes. Upon completion of each stage, further construction can begin only after the inspection occurs and approval is granted. Inspections of construction and renovation will occur, at a minimum, at the following stages:
 - (a) Upon completion of inspection footings and foundations;
 - (b) Upon completion of inspection rough-in, rough wiring, and plumbing; and
 - (c) At final completion.
16. Contractor agrees to warranty all work for one calendar year following the completion of the project.
17. Contractor shall at all times keep the work area clean, including storage areas free from accumulations of waste materials. Contractor shall post all proper documentation for this project. After completing the work and before the final inspection, Contractor shall remove all equipment, tools, materials, the work area shall be left in a clean, neat and in an orderly condition.

18. Contractor shall provide a final report to Tribal representatives that identifies specific details regarding any previously approved variances to the provided design with all manufacturer appliance manuals and/or operating instructions.

6 GENERAL REQUIREMENTS

6.1 Term of Service

The agreement resulting from this ITB shall be effective from the date of execution of the agreement through the completion of services. In no event shall services under the agreement extend beyond September 30, 2025. In the event the work is not completed within this timeframe, the Tribe, in its sole opinion, may determine the contractor to be in breach of the terms of the agreement.

6.2 ITB Modification

The Tribe reserves the right to:

- a) Modify or otherwise alter any or all of the requirements herein. In the event of a modification, contractors will be given an equal opportunity to modify their proposals as identified in writing by the Tribe.
- b) Reject any proposal not adhering to the requirements set forth within this ITB, either in whole or in part.
- c) Reject any or all proposals received.
- d) Terminate this ITB at any time without reason.

6.3 Order of Precedence in the Event of a Conflict

If an agreement is awarded, all terms and conditions herein shall be incorporated into the award. Any change to the agreement must be through a written amendment agreed upon by both Parties.

6.4 Subcontracting

The contractor must disclose to the Tribe the use and identity of all subcontractors it uses in carrying out the requirements herein. The Tribe reserves the right to approve all subcontractors if it so chooses. The contractor is solely responsible for the satisfactory performance of and compensation to any and all subcontractors.

6.5 Insurance and Bonding

The contractor shall have, maintain, and provide proof of Commercial General Liability Insurance and Workman's Compensation Insurance, in addition to any applicable insurance required by the State of Alaska or the contractor's primary state of location. The contractor must provide the Tribe with proof of the insurance required herein. The contractor shall be financially responsible for all deductibles, costs, and self-insured retentions and/or self-insurance required herein.

The Tribe is a sovereign nation, and as such the contractor waives all rights against the Tribe and its officers, employees, and agents for recovery of damages to the extent these damages are covered by the required policies.

Following execution of the agreement, the contractor will furnish a performance bond and a payment bond, each in an amount equal to 100% of the contract price, as security for the faithful performance and payment of the contractor's obligations under the agreement.

6.6 Indemnification

Except in the case of the sole negligence or willful misconduct of the Tribe, the contractor shall indemnify, defend and hold harmless the Tribe, and the Tribe's officers, agents, and employees from and against any and all liability, claims, damages, losses, expenses, actions, attorney fees and costs and lawsuits whatsoever (including without limitation all claims involving damage to real or personal property, civil rights claims, or claims of infringement of a patent, copyright, trade secret or trademark) caused by or arising out of the performance, acts, or omissions under this ITB by the contractor or any of its officers, agents, representatives, employees or subcontractors or arising from or related to a failure to comply with the requirements herein, and/or applicable state or federal statute, law, regulation, or rule.

Nothing in this ITB is a waiver of Sovereign Immunity.

7 PRICE AND PAYMENT

7.1 Proposal Price

The contractor must submit a written price proposal to provide the good(s) or service(s) as specified herein. The proposed price must include all of the contractor's costs associated with providing the good(s) or service(s) as called for within this ITB and including, but not limited to, wages, administrative overhead, travel, transportation, lodging, and other similar costs unless stated otherwise. No other costs will be considered for payment.

7.2 Payment

The contractor shall be paid for actual work completed in accordance with the requirements herein and the accepted price proposal. The total amount to be paid to the contractor shall not exceed the contractor's quoted amount unless otherwise specifically agreed to in advance with supporting justification and in writing by both parties.

Payment to the contractor is contingent on the contractor delivering a bill or invoice to the Tribe on a monthly basis. The Tribe retains the right to require additional documentation to support the submitted invoice. The Tribe will provide payment to the contractor within 30 calendar days of acceptance of the invoice.

The contractor shall provide the following information with each monthly invoice:

- a)** Identification of billing period
- b)** A statement describing the actual work completed with sufficient detail to reconcile the charges against the work performed and/or work product received by the Tribe;
- c)** Percentage of services completed per phase of the Project, per the contractor's schedule of values;

- d) Date invoice was submitted;
- e) Entity name and contact information; and

f) Name of authorized person originating or submitting the billing for the entity. Each covered contractor and subcontractor must provide the Kenaitze Indian Tribe with a copy of all payrolls for the preceding weekly payroll period on a weekly basis.

Each payroll submitted must be accompanied by a "Statement of Compliance." The contractor, subcontractor, or the authorized officer or employee of the contractor or subcontractor who supervises the payment of wages must sign the weekly statement.

8. TYPE OF AGREEMENT

Within thirty (30) calendar days after the Notice of Award is issued, it is expected that the Selected Offeror will sign the Tribe's Standard Professional Service Agreement, which is included with the ITB information as Attachment B. Offerors are expected to carefully review the Tribe's Standard Professional Service Agreement and advise the Tribe in their proposal if any of the terms or conditions of the Standard Professional Service Agreement are objectionable. If any provisions are objectionable, the Offeror must provide in redline format alternative terms and conditions that are acceptable to it, along with the reasons for the proposed changes. These pages will not count against the proposal page limit. The Tribe reserves the right to reject any proposal that fails to indicate that the Offeror is willing to execute the Tribe's Standard Professional Service Agreement or fails to propose alternative terms and conditions that are acceptable to the Tribe.

9. INSURANCE, CERTIFICATIONS, AND OTHER REQUIREMENTS

9.1 Bid Guarantee: Pursuant to 2 C.F.R § 200.326, Offerors are required to provide a bid guarantee equivalent to five percent (5%) of the proposed Price. The bid guarantee may be a cashier's check, certified check, bank money order, or bank draft, in any case drawn and issued by a national banking association located in the State of Alaska or by any banking corporation incorporated under the laws of the State of Alaska, or a bid bond secured by a surety company acceptable to the U.S. Government and authorized to do business in Alaska. The bid guarantee must be made payable to Kenaitze Indian Tribe. Bid guarantees submitted by unsuccessful Offeror will be returned as soon as practicable after award of the Agreement.

9.2 Insurance: If Offeror is selected, Offeror must agree to maintain the level of insurance coverage specified in the Agreement throughout construction of the Project.

9.3 Certifications Required for Federally Funded Projects: By submitting a proposal, the Offeror assures that:

9.3.1 Neither it nor any of its principals is presently debarred, suspended, proposed for debarment, or declared ineligible or voluntarily excluded from participation in this transaction by any state or federal department or agency;

9.3.2 Neither the Offeror, nor any of its employees, agents, or representatives has violated the provisions of the "Anti-Kickback" Act (41 U.S.C §§ 8701-8707) which will be incorporated by reference and made a part of any contract;

- 9.3.3 Buy America Requirements. The contractor agrees to comply with 49 U.S.C. 5323(j) and 49 C.F.R. part 661 and 2 CFR § 200.322 Domestic preferences for procurements, which provide that Federal funds may not be obligated unless all steel, iron, and manufactured products used are produced in the United States;
- 9.3.4 Neither the Offeror nor any of its representatives has been required, directly or indirectly, as an express or implied condition in obtaining or carrying out this contract, to employ or retain any organization or person or to make a contribution, donation, or consideration of any kind;
- 9.3.5 It will comply with all applicable state and federal rules governing Equal Employment Opportunity and Non-Discrimination, including all applicable provisions of 41 C.F.R § 60–1.4(b); and
- 9.3.6 Its prices were independently arrived at and without collusion.
- 9.3.7 To the extent required by applicable law and consistent with the obligations contained in the Agreement, Offeror are advised that – prior to the execution of the Agreement – the successful Proposer may be required to submit certain additional certifications, including but not limited to: (1) a certification regarding compliance with Worker’s Compensation and other applicable labor requirements; (2) a Drug-Free Work Place Certification, and (3) any additional certifications required by applicable federal law.

9.4 License: All Offerors are required to hold a valid Alaska Business License, a valid General Contractor's License, and a valid Professional License sufficient to perform the work required by the Project. All services performed under the Agreement resulting from this ITB which may require a professional license shall be performed by or under the supervision of a person licensed and registered in the State of Alaska to provide the services contemplated under the Agreement. Offerors must submit copies of all licenses, certificates, registrations, and other credentials required for performance under the contract when submitting proposals in response to this ITB. Documentation must be current and must have been issued by or under authority of the State of Alaska or, if documentation is from an outside jurisdiction, such documentation must be accepted as valid by the State of Alaska for performance in Alaska.

10. ADDITIONAL REQUIREMENTS:

The Offeror is responsible for conducting necessary research and becoming familiar with the organization as necessary. **A site inspection is required** for submission of a proposal on this project to verify existing conditions and for Offeror to familiarize itself with the full scope of work. Contact Tami Murray, Procurement Manager, to arrange an inspection at 907-335-7213 or TMurray@kenaitze.org.

11. GENERAL REQUIREMENTS

11.1 Term of Service

The agreement resulting from this ITB shall be effective from the date of execution of the agreement through the completion of services. The Tribe anticipates that the Project will be completed by September 30, 2025.

11.2 ITB Modification

Offerors should be aware that the Project information presented in this document is preliminary. Descriptions of the Project and proposed schedule are subject to refinement and change to meet the ongoing needs of the Project. The Tribe reserves the right to accept or reject any or all submittals, consider alternatives, waive informalities in evaluation procedures and ITB requirements, and may make its selection based on any factors deemed to serve its own best interest. This includes the right to reject any or all proposals and the right to proceed utilizing a different procurement process. The Tribe, in its sole discretion, may cancel the solicitation at any time if such cancellation is in the best interest of the Tribe.

11.3 Sub-consultants

The Selected Offeror must disclose to the Tribe the use and identity of sub-consultants it intends to use in carrying out the requirements herein. The Tribe reserves the right to approve all sub-consultants if it so chooses. The Selected Offeror is solely responsible for the satisfactory performance of and compensation to any sub-consultants.

The Tribe has adopted a Tribal Employment Rights Ordinance (TERO), Ordinance No. 2017-01. In accordance with the TERO, the Selected Offeror shall make best efforts to employ and subcontract with Tribal members, Tribal members' spouses, and other Alaska Native and American Indians. The Selected Offeror shall review and consider the Tribe's preferred vendor list and index of Tribal members and eligible Indians seeking employment maintained by the TERO office.

11.4 Other

The Tribe may require, seek, and utilize all information it deems appropriate to assess the qualifications of individual Offerors. Unless otherwise specified by Offeror in writing, all proposal information submitted in response to this ITB shall be considered public information and may, at the Tribe's sole discretion, be released to the public at the conclusion of the procurement process, except for the rate information submitted in response to the pricing criteria. Any other information related to pricing or capacity that Offerors consider confidential or proprietary must be clearly identified in writing as part of the Proposal response.

12. EVALUATION AND SELECTION

Proposals will be evaluated by staff based upon the responsiveness to the submission requirements described in Section 4, and/or the following point system, and/or any other manner deemed appropriate by the Tribe to determine the proposal most advantageous to the Tribe.

Point System:

- ***Capability and Experience (20 points)***

Provide a summary of the proposed project team, identifying the primary point of contact for the Tribe throughout the project and relevant experiences for the identified individual. List all subcontractors that will play a key role in the project and describe their relevant experiences.

- **Work Plan (20 points)**
Provide a detailed work plan that outlines the timeline for all phases of the project, including, but not limited to, the starting date and other milestones/deadlines for each phase.
- **Proposal and Professionalism (10 points)**
Provide a comprehensive and professional proposal with all key elements as stated herein.
- **Value Proposal (50 points)**
The Tribe will award these points based on the vendor's quoted price.
- **Alaska Native/American Indian Member (10 points) or Tribal Member (25 points) Preference**
Provide proof of AN/AI membership or Tribal membership for the vendor's owner to receive preference. In order to be considered for preference, proof of membership and at least 51% ownership must be submitted with the proposal.

The Tribe reserves the right to waive informalities and minor inaccuracies and reject any and/or all proposals which it deems to be not in the best interests of the Tribe and to proceed with the next proposer or to utilize an entirely different process at any time during the process.

The anticipated date for the Notice of Award is November 11, 2024
Anticipated Completion of the project by September 30, 2025.

ATTACHMENTS:

Attachment A – Construction Drawings

Attachment B - Standard Professional Service Agreement

Attachment C - Project Site Plot Plan & Boundary Survey

End of Proposal

Kenaitze Indian Tribe Senior Housing

KENAI, ALASKA

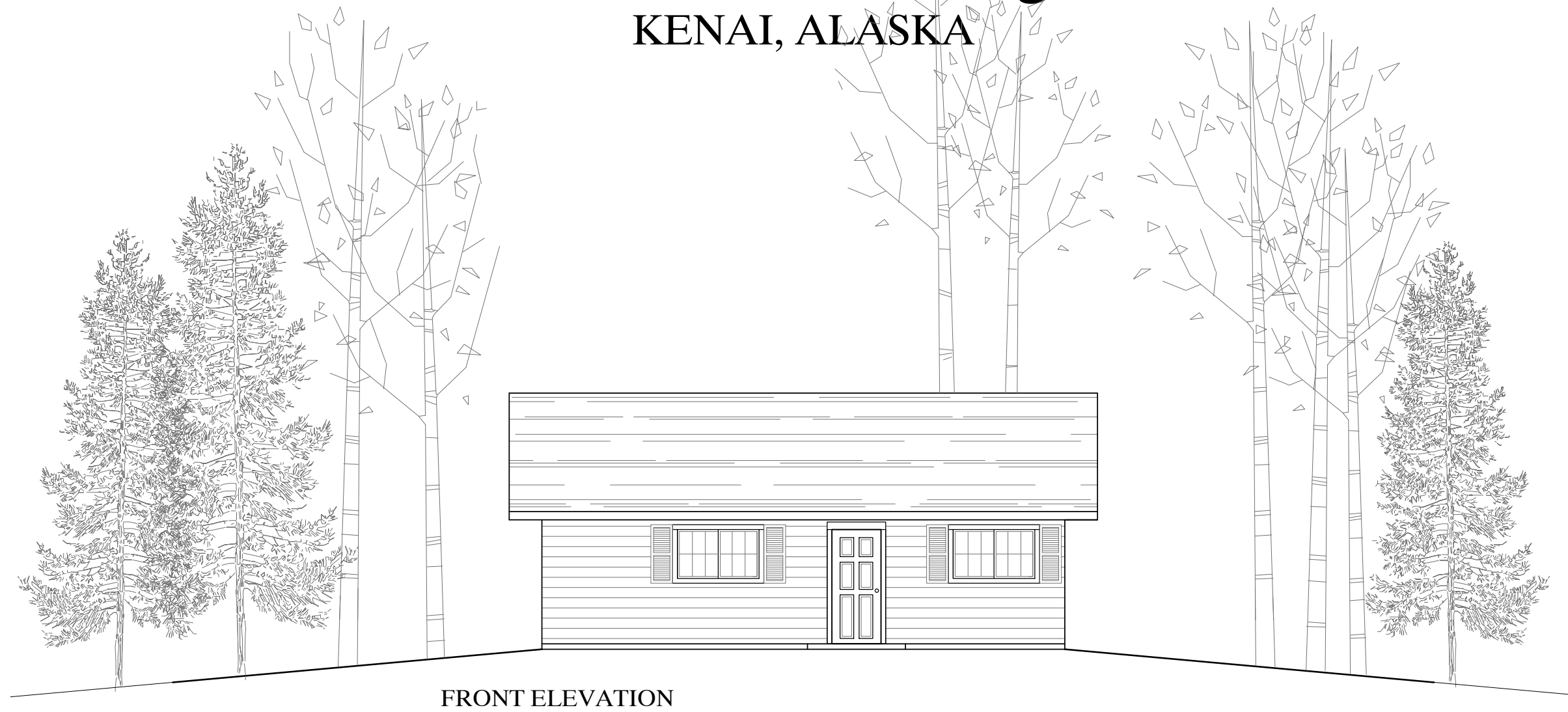

FRONT ELEVATION

CONTENTS

- A1.0 GENERAL NOTES AND SYMBOLS
- A2.0 FLOOR PLAN & INTERIOR ELEVATIONS
- A3.0 ELEVATIONS



KENAI, ALASKA



Kimber Graham
4520 Kenaitze Court
Kenai, Alaska 99611
draftalaska@gmail.com
907.201.0931

GENERAL NOTES

1. THE CONTRACTOR SHALL ASSUME ALL RESPONSIBILITY TO ENSURE THAT ANY WORK NOT COVERED IN THESE DOCUMENTS OR ANY MODIFICATIONS MADE DURING CONSTRUCTION ARE IN COMPLIANCE WITH ALL APPLICABLE CODES AS LISTED ABOVE. THE DESIGNER SHALL BE NOTIFIED PRIOR TO ANY MODIFICATIONS.
2. WHEN WORK NOT SPECIFICALLY CALLED OUT IS REQUIRED TO COMPLETE THE PROJECT, IT SHALL BE OF THE BEST MATERIAL AND WORKMANSHIP.
3. CONTRACTOR SHALL TAKE ALL NECESSARY PRECAUTIONARY MEASURES TO PROTECT THE PUBLIC AND ADJACENT PROPERTIES FROM DAMAGE THROUGHOUT CONSTRUCTION. CONTRACTOR ASSUMES ALL LIABILITY FOR DAMAGES INCURRED DURING CONSTRUCTION.
4. ALL WORK SHALL BE CARRIED FORTH IN COMPLIANCE WITH ALL APPLICABLE BUILDING AND ZONING CODES AND ORDINANCES, WITH ALL GOVERNMENTAL AUTHORITIES HAVING JURISDICTION, AND PERFORMED WITHIN THE STANDARDS OF THE APPLICABLE TRADE ASSOCIATION.
5. ALL APPLICABLE CODES, ORDINANCES AND MINIMUM STRUCTURAL REQUIREMENTS TAKE PRECEDENCE OVER THE DRAWINGS AND NOTES.
6. CONTRACTOR SHALL VISIT THE SITE AND EXAMINE ALL CONDITIONS RELATED TO THE WORK. THE CONTRACTOR SHALL REPORT ANY ERRORS, OMISSIONS OR UNFORESEEN CONDITIONS TO THE DRAFTSMAN PRIOR TO THE COMMENCEMENT OF WORK.
7. CONTRACTOR SHALL TAKE WHATEVER STEPS NECESSARY TO PROTECT FROM DAMAGING EXISTING CONDITIONS. ANY DAMAGE TO NEW OR EXISTING WORKS SHALL BE REPAIRED OR REPLACED TO THE TDHE'S/LANDLORD'S SATISFACTION BY THE CONTRACTOR.
8. CONTRACTOR SHALL CAREFULLY EXAMINE ALL CONTRACT DOCUMENTS AND SHALL COORDINATE THE WORK WITH ALL TRADES, INCLUDING BUT NOT LIMITED TO, STRUCTURAL, ELECTRICAL, MECHANICAL, PLUMBING, CIVIL AND SPECIALTY DRAWINGS INCLUDING SHOP DRAWINGS AND MATERIAL SPECIFICATIONS.
9. DIMENSIONS ARE TO FACE OF STUD UNLESS OTHERWISE NOTED.
10. THE CONTRACTOR SHALL BE RESPONSIBLE FOR VERIFYING ALL EXISTING CONDITIONS, DIMENSIONS, AND MEMBER SIZES PRIOR TO THE START OF ANY WORK AND MUST ADAPT HIS WORK TO ACTUAL CONDITIONS IN A MANNER APPROVED BY THE DRAFTER AND TDHE'S REPRESENTATIVE. FAILURE TO CONTACT THE DRAFTER OR TDHE'S REPRESENTATIVE DOES NOT RELIEVE THE CONTRACTOR OF ANY LIABILITY.
11. THE DRAWINGS INDICATE ONLY A DIMENSIONAL GRAPHIC REPRESENTATION OF THE WOOD STUDS WITH RESPECT TO THE SURROUNDING FINISHES. ADHERING TO THE PROCEDURE ESTABLISHED IN THE NOTES BELOW SHALL BE THE GENERAL CONTRACTOR'S RESPONSIBILITY.
12. THE GENERAL CONTRACTOR SHALL NOT PERMIT HIS REPRESENTATIVES TO MEASURE BY SCALE THE DOCUMENTS, ANY MISSING DIMENSIONS SHALL BE CLARIFIED WITH DRAFTER.
13. THE GENERAL CONTRACTOR WITH HIS PAINT REPRESENTATIVES AND ANY OTHER TRADES CONCERNED SHALL VERIFY AND COORDINATE ALL COLORS, TEXTURES, PATTERNS, ETC. TO BE APPROVED BY TDHE PRIOR TO COMMENCING THE PAINT WORK TO AVOID ANY UNNECESSARY CORRECTIVE WORK.
14. TDHE WILL NOT BE RESPONSIBLE FOR:
 - a. SECURITY OF MATERIAL OR WORK IN PLACE
 - b. WARRANTY REPAIRS
 - c. WINDOW BREAKAGE DURING CONSTRUCTION OR DISMANTLING OF BASE BUILDING SYSTEMS OR CONSTRUCTION
12. THE CONTRACTOR WILL SECURE THE NECESSARY BUILDING PERMITS AND INSPECTIONS.
13. ALL MATERIALS WILL BE NEW UNLESS OTHERWISE PROVIDED BY TDHE.
14. THE CONTRACTOR WILL FURNISH ALL MATERIALS REQUIRED FOR THE ASSEMBLIES IN WHICH THEY ARE PART. THIS INCLUDES ALL FASTENERS, JOINERS AND SEALERS.
15. THE CONTRACTOR WILL REMOVE ALL TRASH AND DEBRIS, INCLUDING EXCESS MATERIALS FROM THE CONSTRUCTION SITE AND THE BUILDING SO THAT AN UNREASONABLE ACCUMULATION WILL NOT OCCUR.

16. THE CONTRACTOR WILL SUPPLY BUILDING STANDARD LOCKS, KEYED TO THE BUILDING MASTER KEY SYSTEM, ACCORDING TO ALL ACCESSIBLE STANDARDS AS APPLICABLE.
17. THE CONTRACTOR SHALL PROVIDE TEMPORARY BRACING FOR STRUCTURAL COMPONENTS UNTIL ALL FINAL CONNECTIONS HAVE BEEN COMPLETED.
18. THE CONTRACTOR WILL EXERCISE ALL DUE DILIGENCE IN MAINTAINING A SAFE WORKING ENVIRONMENT AND TO ABIDE BY ALL WORK SAFE BC REGULATIONS AND ALL SAFETY REQUIREMENTS OF THE LOCAL MUNICIPAL AND PROVINCIAL BUILDING CODES.
19. ALL ELECTRICAL CIRCUITS (NEW AND EXISTING) SHALL BE IDENTIFIED AND LABELED IN THE ELECTRICAL PANEL.
20. THE DRAFTER SHALL NOT HAVE CONTROL OF, BE IN CHARGE OF, OR BE RESPONSIBLE FOR CONSTRUCTION MEANS, METHODS, TECHNIQUES OR PROCEDURES, OR THE SAFETY PRECAUTIONS AND PROGRAMS IN CONNECTION WITH THE WORK, FOR THE ACTS OR OMISSIONS OF THE CONTRACTOR, SUBCONTRACTOR, OR ANY OTHER PERSONS INVOLVED WITH THE WORK, OR THE FAILURE OF ANY OF THEM TO CARRY OUT THE WORK IN ACCORDANCE TO THE CONTRACT DOCUMENTS.
21. THE CONTRACTOR SHALL PROTECT ALL SURFACES ADJACENT TO THE WORK AREA. REPLACEMENT OF DAMAGED AREAS SHALL BE AT THE CONTRACTOR'S EXPENSE.
22. FOR SECURITY PURPOSES, THE CONTRACTOR IS TO COORDINATE WITH TDHE PRIOR TO THE START OF WORK.
23. THE CONTRACTOR WILL COORDINATE WITH ALL UTILITIES HAVING JURISDICTION FOR THE POSSIBLE REPAIR AND OR REPLACEMENT OF SERVICES.
24. THE CONTRACTOR IS RESPONSIBLE FOR COORDINATING WITH ALL AGENCIES HAVING JURISDICTION CONTROL OVER THE PROJECT.
25. UNLESS OTHERWISE NOTED, ALL DETAILS, SECTION AND NOTES ARE INTENDED TO BE TYPICAL FOR SIMILAR SITUATIONS. THE CONTRACTOR TO VERIFY ALL EXISTING CONDITIONS.
26. ALL MATERIAL AND FINISHES ARE TO BE APPROVED BY TDHE PRIOR TO COMMENCEMENT OF THE INSTALLATIONS.
27. UPON COMPLETION, THE CONTRACTOR WILL REMOVE ALL FOREIGN MATERIALS FROM ALL SURFACES INCLUDING, BUT NOT LIMITED TO THE FOLLOWING: WINDOWS, FLOORS, CEILINGS, GLASS, MIRRORS, ELECTRICAL EQUIPMENT, PLUMBING, HARDWARE AND RESTROOM FIXTURES AND SHALL TURN OVER THE BUILDING IN A CLEAN CONDITION.
28. CONTRACTOR SHALL ESTABLISH AND VERIFY ALL OPENINGS AND INSERTS FOR MECHANICAL, ELECTRICAL, AND PLUMBING WITH APPROPRIATE TRADES.
29. CONTRACTOR SHALL PROVIDE ALL NECESSARY TEMPORARY BRACING, SHORING, GUYING, OR OTHER MEANS TO AVOID EXCESSIVE STRESSES AND TO HOLD STRUCTURAL ELEMENTS IN PLACE DURING CONSTRUCTION.
30. ALL UNTESTED COMPONENTS, EQUIPMENT, ETC., SHALL BE INSTALLED PER MANUFACTURER'S PRINTED RECOMMENDATIONS.
31. FRAMING CONTRACTOR TO VERIFY ROUGH OPENING SIZES AND DETAILS FOR DOORS, WINDOWS, EXHAUST FANS, VENTS, ETC..
32. PROVIDE PRESERVATIVE TREATED AWW FOR SILL PLATES AND ALL CONCRETE TO WOOD CONNECTIONS.
33. ALL GWB SHALL BE 5/8" TYPE X UNLESS NOTED OTHERWISE. GWB ON WALLS SHALL BE 1/2" UNLESS OTHERWISE NOTED.
34. PROVIDE GWB CONTROL JOINTS NOT TO EXCEED 30'-0" SPACING.
35. PROVIDE MINIMUM 24" NFS MATERIAL AROUND ALL FOOTINGS.
36. INSTALL CONTINUOUS 4" PERFORATED DRAIN TILE (FABRIC WRAPPED) ALONG PERIMETER FOOTONG.
37. PROVIDE A MINIMUM OF 6" CLEARANCE FROM FINISH GRADE TO WOOD THAT IS NOT PRESERVATIVE TREATED AWW. SLOPE FINISH GRADE AWAY FROM FOUNDATION WALL A MINIMUM OF 6" WITHIN THE FIRST 10' EXCEPT AS RESTRICTED BY LOT LINES.
38. PROVIDE MINIMUM 22" X 30" ATTIC ACCESS.

39. PROVIDE MINIMUM 4" CLEAR ABOVE ATTIC INSULATION FOR VENTILATION UNLESS NOTED OTHERWISE.
40. PROVIDE DOUBLE TOP PLATE WITH MINIMUM 48" OFFSET AT SPLICES.
41. PROVIDE CONTINUOUS PERFORATED ALUMINUM SOFFIT AT LOW EAVES FRONT AND BACK. PROVIDE RIDGE VENTS AND HALF RIDGE VENTS.
42. PROVIDE AN APPROVED FLASHING FOR EXTERIOR OPENINGS.
43. PROVIDE CONTINUOUS 6 MIL VAPOR RETARDER. TAPE ALL SEAMS AND PUNCTURES.
44. PROVIDE A WEATHER-PROTECTIVE BARRIER UNDER SIDING, "TYVEK" OR EQUAL.
45. APPLY FOUNDATION INSULATION ON COLD SIDE OF FOUNDATION WALL UNLESS NOTED OTHERWISE.
46. PROVIDE GFCI RECEPTACLES WITHIN 6'-0" OF SINKS. PROVIDE GFCI RECEPTACLES WITH WATERPROOF COVERS AT ALL OUTDOOR LOCATIONS.
47. PROVIDE MINIMUM NOMINAL 6" PLUMBING WALLS.
48. ALL HOSE BIBBS TO BE ANTI-SIPHON FROST FREE.
49. HEAT PRODUCING APPLIANCES REQUIRE SEISMIC BRACING PER ASCE-7, SECTION 13.6 BY OTHERS.
50. GAS OR ELECTRIC METER BASES SHALL BE PROTECTED FROM SLIDING ICE.
51. PROVIDE AT LEAST ONE WINDOW WITH A MINIMUM OF 5.7 SQ FT NET CLEAR OPENING WITH A MINIMUM OF 24" IN HEIGHT AND 20" IN WIDTH, OR AN EXTERIOR DOOR APPROVED FOR EMERGENCY ESCAPE OR RESCUE FROM BASEMENTS AND FROM EVERY ROOM USED FOR SLEEPING PURPOSES.
52. PROVIDE CARBON MONOXIDE AND SMOKE DETECTORS PER IBC. WIRE IN SERIES WITH BATTERY BACKUP.
53. PROVIDE A GRIPPABLE HANDRAIL MAXIMUM 2" DIA FOR STAIRWAYS ON BOTH SIDES. HANDRAILS SHALL NOT BE LESS THAN 34" NOR MORE THAN 38" ABOVE THE NOSING TREAD.
54. PROVIDE GUARD RAIL BARRIER NO LESS THAN 3'-6" IN HEIGHT FROM WALKING SURFACE AT ALL RAMP, STAIR, AND DECK AREAS. OPEN GUARDS SHALL HAVE BALUSTERS SUCH THAT A (4)-INCH DIAMETER SPHERE CANNOT PASS THROUGH ANY OPENING.
55. INSTALL CEMENTITIOUS BOARD AS SUBSTRATE FOR ANY WALL TILE INSTALLATION.
56. SINKS SHOWN ON THESE DRAWINGS INDICATE LOCATIONS ONLY AND NOT ACTUAL SIZES OR TYPES. THE CONTRACTOR SHALL BE RESPONSIBLE FOR PROVIDING AND COORDINATING ACTUAL SIZES AND TYPES WITH CABINET FABRICATOR PRIOR TO CONSTRUCTION.
57. BLOCKING FOR CABINETS IS NOT SHOWN ON THESE DRAWINGS. CONTRACTOR SHALL BE RESPONSIBLE FOR PROVIDING AND COORDINATING WALL BLOCKING FOR CABINETRY. WHERE WOOD BLOCKING IS PROHIBITED BY CODE, PROVIDE GALVANIZED STEEL SHEET BLOCKING.
58. PROVIDE BRACES FOR UNSUPPORTED COUNTER TOPS AT 4'-0" O.C. MAXIMUM. INDICATE LOCATION OF BRACES ON SHOP DRAWINGS. BRACES HAVE BEARING DEPTH OF AT LEAST 2/3 THE DEPTH OF THE SURFACE BEING BRACED. PROVIDE BRACES WITH A 90 DEGREE ANGLE BETWEEN THE HORIZONTAL AND VERTICAL LEGS.
59. HORIZONTAL CABINET DIMENSIONS SHOWN ON DRAWINGS MAY BE MODIFIED TO ACCOMMODATE FIELD CONDITIONS.
60. BLOCKING FOR GRAB BARS AROUND TOILET AND IN SHOWER IS NOT SHOWN ON THESE DRAWINGS. CONTRACTOR SHALL BE RESPONSIBLE FOR PROVIDING AND COORDINATING WALL BLOCKING FOR GRAB BARS. WHERE WOOD BLOCKING IS PROHIBITED BY CODE, PROVIDE GALVANIZED STEEL SHEET BLOCKING
61. VENT DRYER TO OUTSIDE. VENT DUCT COMBINED TOTAL DISTANCE SHALL NOT EXCEED 14'-0" WITH NO MORE THAN (2) EACH 90° ELBOWS.
62. CLEARANCE FROM COMBUSTIBLES SHALL BE PER MANUFACTURER'S WRITTEN SPECIFICATIONS.
63. THE RE-USE OF THESE DOCUMENTS TO CONSTRUCT FUTURE BUILDING PROJECTS SHALL REQUIRE REVIEW BY THE DRAFTER.







DESIGNER DISCLAIMER

1. WE HAVE EXERCISED GREAT EFFORT AND CARE IN THE CREATION OF THIS HOME DESIGN AND THE COMPLETION OF THESE CONSTRUCTION DRAWINGS. HOWEVER, DRAFT ALASKA, LLC., HAS NOT BEEN CONTRACTED TO PROVIDE PERSONAL CONSULTATION, SITE SUPERVISION OR FIELD INSPECTION SERVICES AND HAS NO CONTROL OVER THE CONSTRUCTION MATERIALS, METHODS OR SEQUENCING USED BY THE BUILDER. FOR THESE REASONS, AS WELL AS THE VARIATIONS IN LOCAL BUILDING CODES, DRAFT ALASKA, LLC., ASSUMES NO RESPONSIBILITY FOR ANY DAMAGES, INCLUDING STRUCTURAL FAILURES RESULTING FROM ERRORS OR OMISSION IN THESE CONSTRUCTION DRAWINGS. YOU MAY CHOOSE, AS THE HOMETDHE, TO HAVE THESE DRAWINGS THOROUGHLY REVIEWED BY A LICENSED ARCHITECT, PROFESSIONAL ENGINEER, OR GENERAL CONTRACTOR LICENSED TO PRACTICE IN YOUR AREA, IN ADDITION TO YOUR LOCAL BUILDING OFFICIALS, PRIOR TO BEGINNING CONSTRUCTION.

BUILDER NOTICE

1. IT IS THE INTENT OF DRAFT ALASKA, LLC. THAT THESE DOCUMENTS BE ACCURATE, PROVIDING LICENSED PROFESSIONALS CLEAR INFORMATION. EVERY ATTEMPT HAS BEEN MADE TO PREVENT ERROR.
2. THE BUILDER AND ALL SUBCONTRACTORS ARE REQUIRED TO REVIEW AND VERIFY ALL CONDITIONS AND DIMENSIONS AND INFORMATION CONTAINED IN THESE DOCUMENTS, BEFORE BEGINNING CONSTRUCTION. CONTRACTOR/BUILDER SHALL ASSUME RESPONSIBILITY FOR ANY PLAN ERRORS, OMISSIONS, OR MISINTERPRETATIONS DETECTED AND NOT REPORTED TO DRAFT ALASKA, LLC. PRIOR TO CONSTRUCTION.
3. ALL CONSTRUCTION MUST BE IN ACCORDANCE TO THE INFORMATION FOUND IN THESE DOCUMENTS. ANY QUESTIONS REGARDING THE INFORMATION FOUND IN THESE PLANS SHOULD BE DIRECTED TO OUR QUALITY ASSURANCE MANAGER AT 907.201.0931 IMMEDIATELY.

SYMBOLS

	CENTERLINE
	WINDOW TAG
	DOOR TAG
	WALL TYPE
	INTERIOR ELEVATION KEY
	BUILDING SECTION KEY
	WINDOW DIMENSIONS

ABBREVIATIONS

AFF	ABOVE FINISH FLOOR
BFF	BELOW FINISH FLOOR
UON	UNLESS OTHERWISE NOTED

THE DRAWINGS, ARRANGEMENTS, PRESENTATIONS OR GRAPHICAL INFORMATION ON THIS PROJECT ARE THE PROPERTY OF DRAFT ALASKA, LLC. AND WILL REMAIN THE SOLE PROPERTY OF THIS DOCUMENT IN ITS ENTIRETY.



KENAITZE INDIAN TRIBE
Senior Housing
 Kenai, Alaska

GENERAL NOTES & SYMBOLS

DRAWN:	K. GRAHAM
JOB:	23.7-KITodo
DATE:	5.24.2024
REVISIONS:	

A1.0

PLOTTED HALF SCALE
 SCALE: AS SHOWN

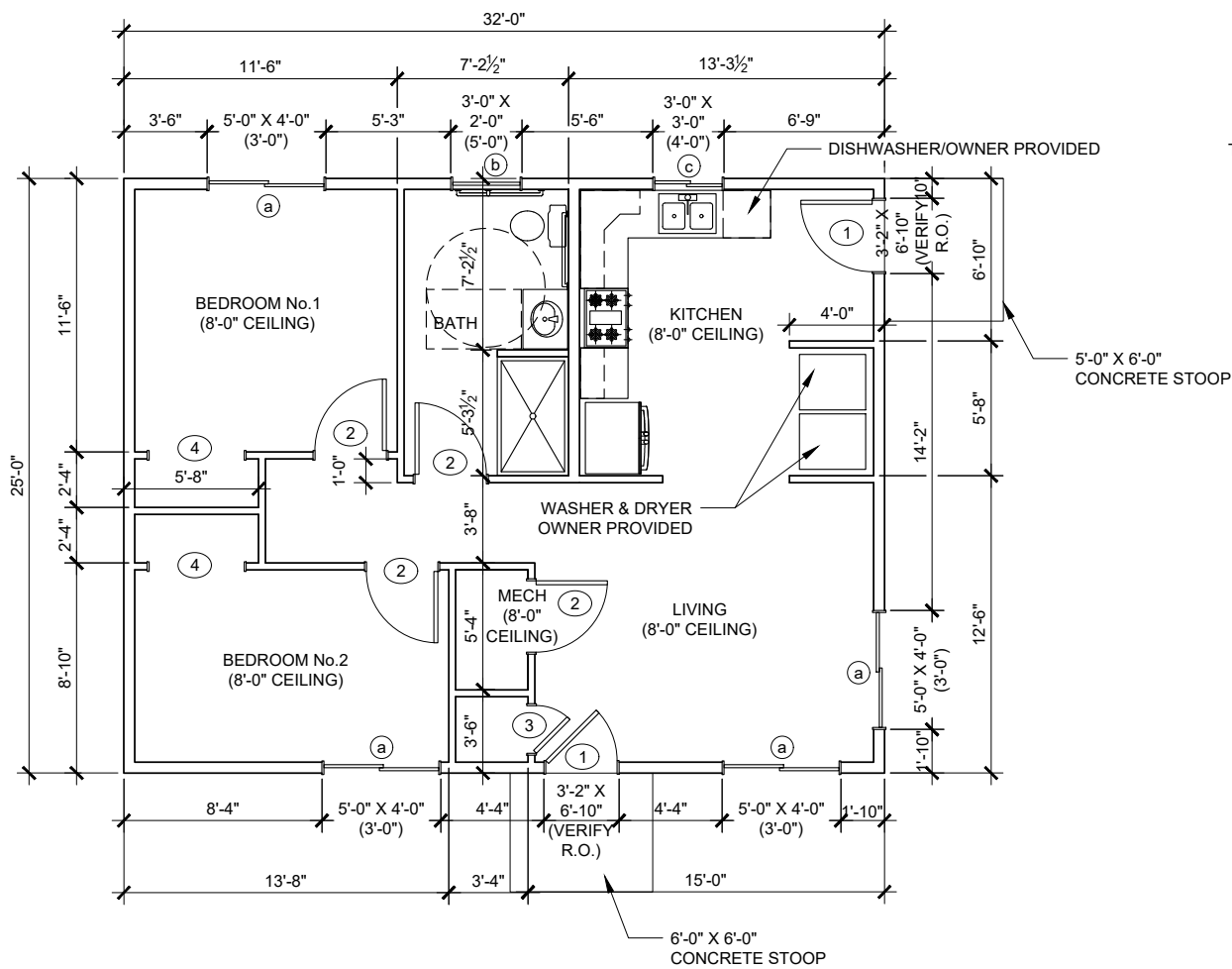

B1 FLOOR PLAN - 800 SF
 1/4" = 1'-0" (22X34); 1/8" = 1'-0" (11X17)

WINDOWS

QUANTITY	TAG	SIZE	TYPE
4	(a)	5'-0" X 3'-0"	SLIDING
1	(b)	3'-0" X 2'-0"	SLIDING
1	(c)	3'-0" X 3'-0"	SLIDING

DOORS

QUANTITY	TAG	SIZE	TYPE
2	(1)	3'-0" X 6'-8"	EXTERIOR
4	(2)	3'-0" X 6'-8"	INTERIOR
1	(3)	2'-0" X 6'-8"	INTERIOR
2	(4)	4'-0" X 6'-8"	FRAMED OPENING

A2 SCHEDULES
 A2.0

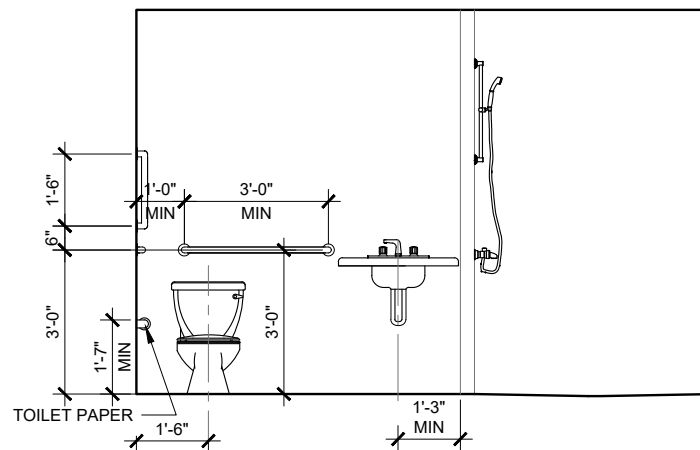

D3 INTERIOR ELEVATION ACCESSIBLE BATHROOM
 1/2" = 1'-0" (22X34); 1/4" = 1'-0" (11X17)

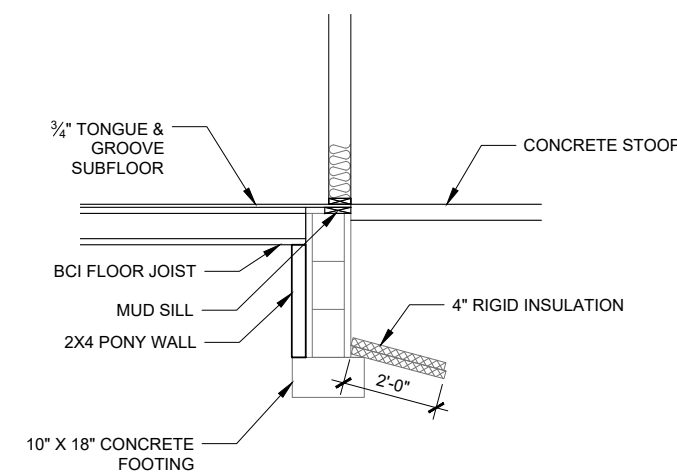

D4 WALL SECTION
 1/4" = 1'-0" (22X34); 1/8" = 1'-0" (11X17)

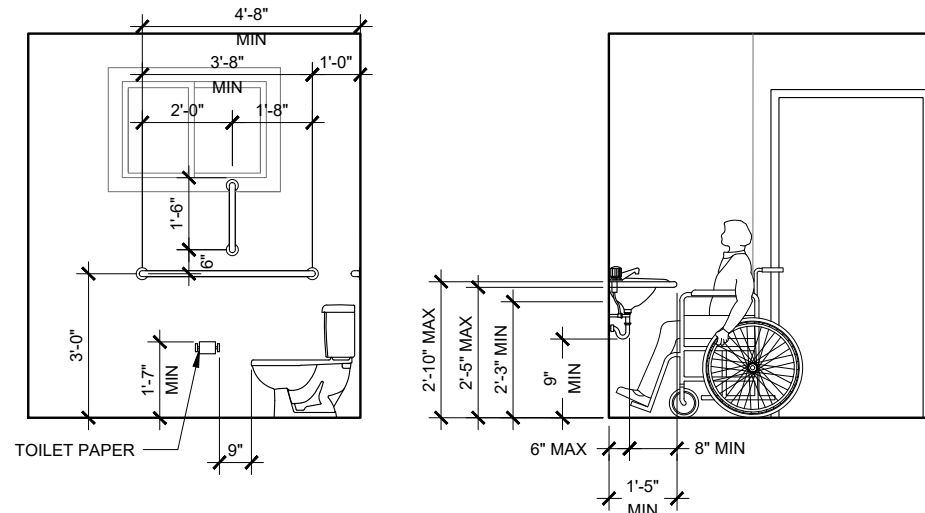

C3 INTERIOR ELEVATIONS - ACCESSIBLE BATHROOM
 1/2" = 1'-0" (22X34); 1/4" = 1'-0" (11X17)

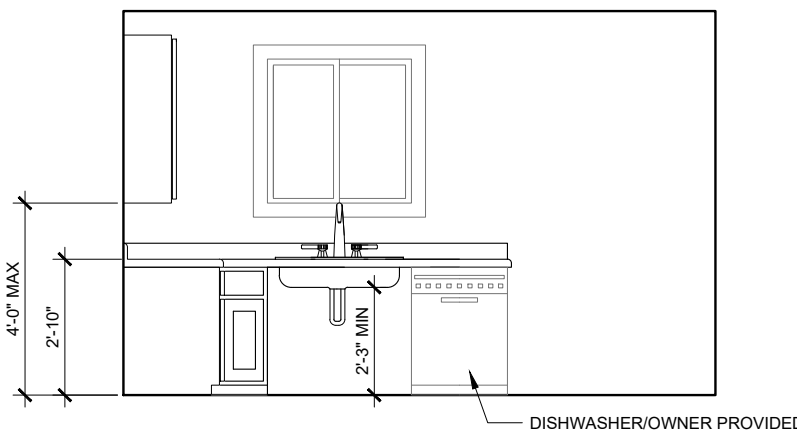

A3 INTERIOR ELEVATIONS - KITCHEN & BEDROOM CLOSET
 1/2" = 1'-0" (22X34); 1/4" = 1'-0" (11X17)

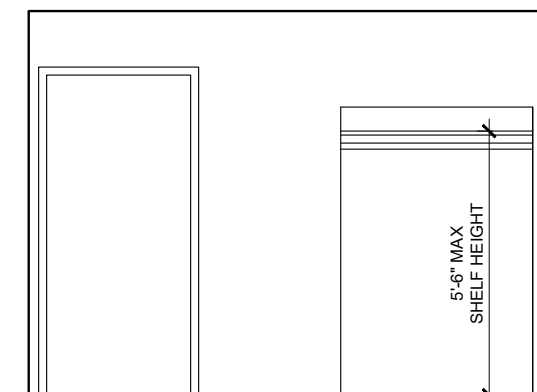

THE DRAWINGS, ARRANGEMENTS, ANNOTATIONS AND GRAPHICAL PRESENTATIONS ON THIS DOCUMENT ARE THE PROPERTY OF DRAFT ALASKA AND WILL REMAIN THE OWNERSHIP OF THIS DOCUMENT IN ITS ENTIRETY. UNLESS OTHERWISE SPECIFIED, ALL RIGHTS ARE RESERVED. NO PART OF THIS DOCUMENT IS TO BE REPRODUCED OR TRANSMITTED IN ANY FORM OR BY ANY MEANS, ELECTRONIC OR MECHANICAL, INCLUDING PHOTOCOPYING, RECORDING, OR BY ANY INFORMATION STORAGE AND RETRIEVAL SYSTEM, WITHOUT THE WRITTEN PERMISSION OF DRAFT ALASKA.



KENAITZE INDIAN TRIBE
Senior Housing
 Kenai, Alaska

FLOOR PLAN

REVISIONS:

NO.	DATE	DESCRIPTION
1	5.24.2024	23.7-KITadd

DRAWN: K GRAHAM
JOB: 23.7-KITadd
DATE: 5.24.2024

A2.0

PLOTTED HALF SCALE
 SCALE: AS SHOWN

1

2

3

4



FRONT ELEVATION
 C2
 A3.0 1/4" = 1'-0" (22X34); 1/8" = 1'-0" (11X17)

ROOF ASSEMBLY:
 ASPHALT SHINGLES OVER
 ICE & WATER SHIELD OVER
 ROOF SHEATHING OVER
 PRE-ENGINEERED TRUSSES WITH
 18" BLOWN IN CELLULOSE INSULATION
 IN TRUSS CAVITY OVER
 6 MIL POLY VAPOR BARRIER OVER
 5/8" TYPE "X" GYPSUM WALL BOARD

EXTERIOR WALL ASSEMBLY:
 SIDING OVER
 "TYVEK" BUILDING WRAP OVER
 WALL SHEATHING OVER
 2X6 STUD WALL OVER
 6" FIBER GLASS BATT INSULATION IN
 STUD CAVITY OVER
 6 MIL POLY VAPOR BARRIER OVER
 1/2" TYPE "X" GYPSUM WALL BOARD

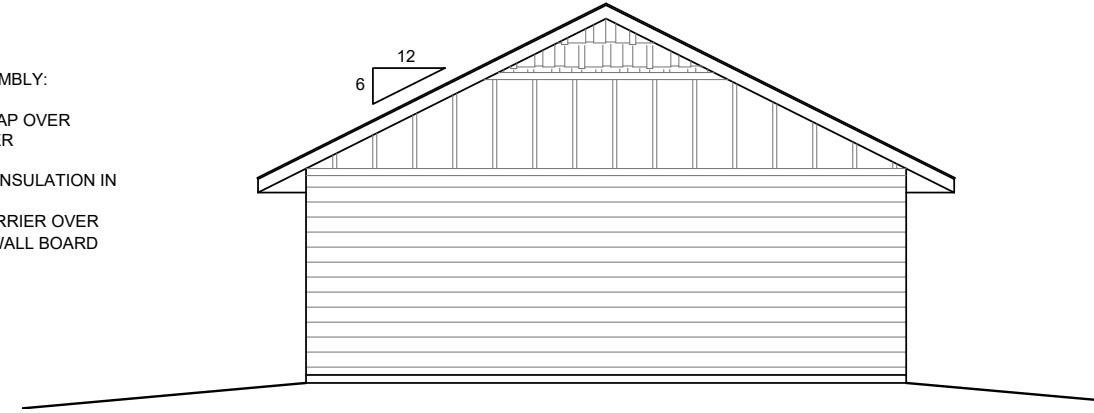

LEFT ELEVATION
 C4
 A3.0 1/4" = 1'-0" (22X34); 1/8" = 1'-0" (11X17)

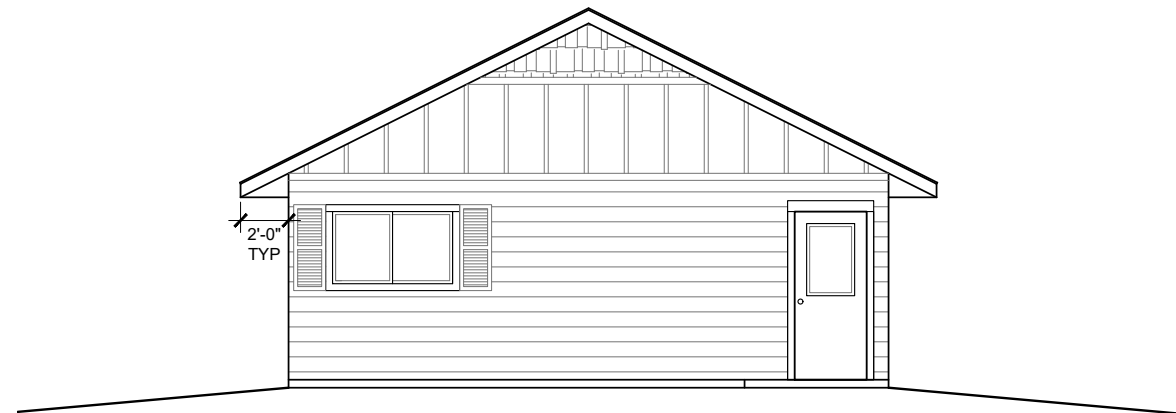

RIGHT ELEVATION
 A1
 A3.0 1/4" = 1'-0" (22X34); 1/8" = 1'-0" (11X17)

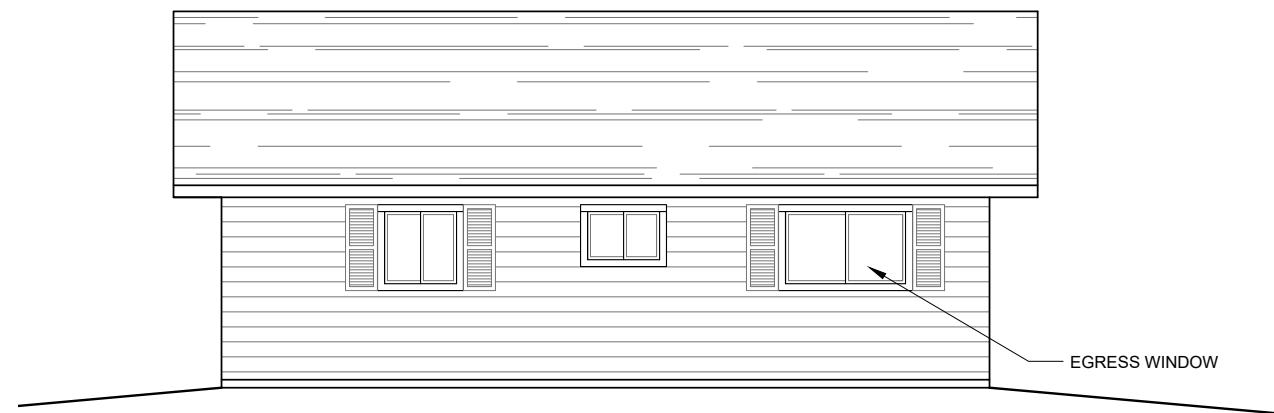

REAR ELEVATION
 A3
 A3.0 1/4" = 1'-0" (22X34); 1/8" = 1'-0" (11X17)

THE DRAWINGS, ARRANGEMENTS, ANNOTATIONS AND GRAPHICAL PRESENTATIONS ON THIS DOCUMENT ARE THE PROPERTY OF DRAFT ALASKA AND THE ARCHITECTS OWNERSHIP OF THIS DOCUMENT IS IN ITS ENTIRETY. UNAUTHORIZED USE OF THIS DRAWING IS GRANTED SOLELY FOR THE PURPOSE OF THIS SPECIFIC PROJECT AND LOCATION, AND NOT FOR ANY OTHER PROJECT.



KENAITZE INDIAN TRIBE
Senior Housing
 Kenai, Alaska

ELEVATIONS

DRAWN:	K GRAHAM
JOB:	23.7-KITroda
DATE:	5.24.2024
REVISIONS:	

A3.0

PLOTTED HALF SCALE
 SCALE: AS SHOWN

LOT 7
BLOCK 1
PLAT 74-32

TRACT D
PLAT 76-07

LEGEND

- ⊕ FOUND PRIMARY MONUMENT
- FOUND PROPERTY CORNER - 1/2" REBAR
- SET PROPERTY CORNER
5/8" X 30" REBAR
WITH 2" ALUMINIUM CAP
STAMPED EDGE SURVEY LS-13022 2023
- (R1) RECORD DATA, SEE REFERENCE
- PROPERTY BOUNDARY
- - - CENTERLINE
- - - ADJACENT PROPERTY LINE
- - - 20 FOOT BUILDING SETBACK
- - - 10 FOOT UTILITY EASEMENT
- - - EDGE LOW WET AREA
- - - EDGE GRAVEL
- ▲ SEPTIC VENT
- Ⓜ WELL

ROBINSON LOOP ROAD 100' RIGHT-OF-WAY

BASIS OF BEARINGS PER (R1) S89°57'15"W 2836.24'

(S89°55'27"W 314.97')(R2)
S89°57'15"W 314.75'

EXISTING HOUSE

PROPOSED SEPTIC AREA

EXISTING SHED

LOT 1A
BLOCK 1
PLAT 93-87

PROPOSED HOUSE

100' PROPOSED SEPTIC SETBACK

LOW WET AREA

PROPOSED WELL

LOT 2
BLOCK 1
PLAT 76-174

PROPERTY CORNER
UNDER WATER
NOTHING FOUND
OR SET

LOT 1B
BLOCK 1
PLAT 93-87

SKEETER STREET
60' RIGHT-OF-WAY

LOT 6
BLOCK 1
PLAT 84-184

(S00°02'09"E 1319.80')(R1)
S00°01'34"E 1319.80'

(N00°02'09"W 151.22')(R2)
N00°01'34"W 151.38'

N00°02'44"W 151.38'
(N00°02'33"W 151.22')(R2)

N00°02'44"W 604.31'
(N00°02'33"W 604.88')(R2)

N89°57'15"E 314.80'
(N89°55'27"E 314.98')(R2)

N

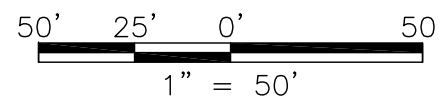
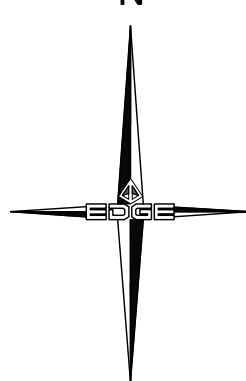

REFERENCES

(R1) STERLING HEIGHTS SUBDIVISION ADDITION NO. 2,
PLAT NO. 76-124, KENAI RECORDING DISTRICT

(R2) STERLING HEIGHTS SCOOTER'S REPLAT,
PLAT NO. 93-87, KENAI RECORDING DISTRICT



8000 KING STREET ANCHORAGE, AK 99518
Phone (907) 344-5990 Fax (907) 344-7794

PLOT PLAN
AND
BOUNDARY
SURVEY

LOT 1A BLOCK 1
STERLING HEIGHT'S
SCOOTER'S REPLAT
PLAT 93-84
KENAI RECORDING DISTRICT
T5N R9W SECTION 11
SEWARD MERIDIAN

DRAFT COPY

DRAWN BY: JY	DATE: 10/12/2023	PROJECT: 23-600
CHECKED BY: RS	SCALE: 1" = 50'	SHEET: 1 OF 1